

Tubular Arch Handles

Tube Aluminum / Stainless Steel, Handle Legs Plastic

SPECIFICATION

Handle tube

Wall thickness 1,5 mm

- Aluminum
 - Powder coated
 - Black, RAL 9005, textured finish **SW**
 - Handle legs / Covers, black, matte finish
 - Anodized, natural color **EL**
 - Handle legs / Covers, black, matte finish
 - Anodized, natural color **ES**
 - Handle legs silver / Covers, light gray, matte finish
- Stainless steel AISI 304
 - Ground, matte shiny finish **NG**
 - Handle legs / Covers, black, matte finish

Handle legs

Aluminum

Powder coated, textured finish

- Black, RAL 9005 for SW / EL / NG
- Silver, RAL 9006 for ES
- Threaded bushing
- Steel, zinc plated

Covers

Plastic, thermoplastic elastomer (TPE)

- Black, matte finish for SW / EL / NG
- Light-gray, matte finish for ES



INFORMATION

With their curved type, GN 666.4 tubular arch handles highlight modern machine design.

The production method used allows special solutions with other radii of curvature or other leg heights.

TECHNICAL INFORMATION

- Load Rating Information (see page A35)
- Plastic Characteristics (see page A2)
- Stainless Steel Characteristics (see page A26)

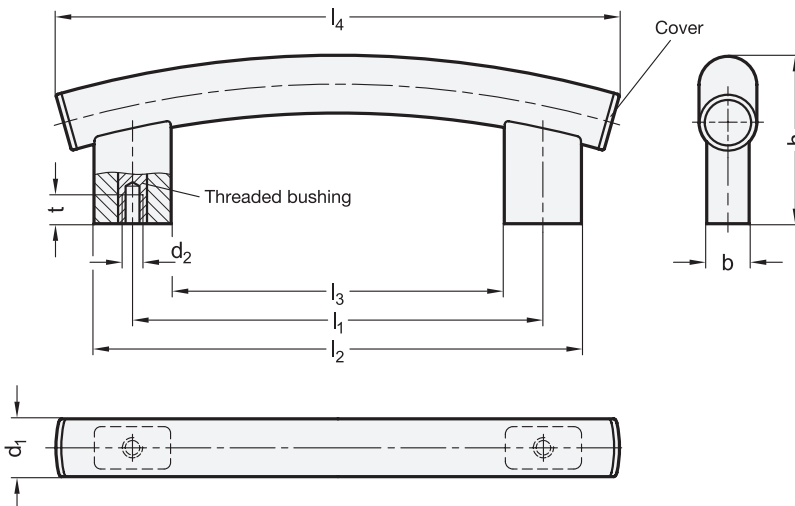

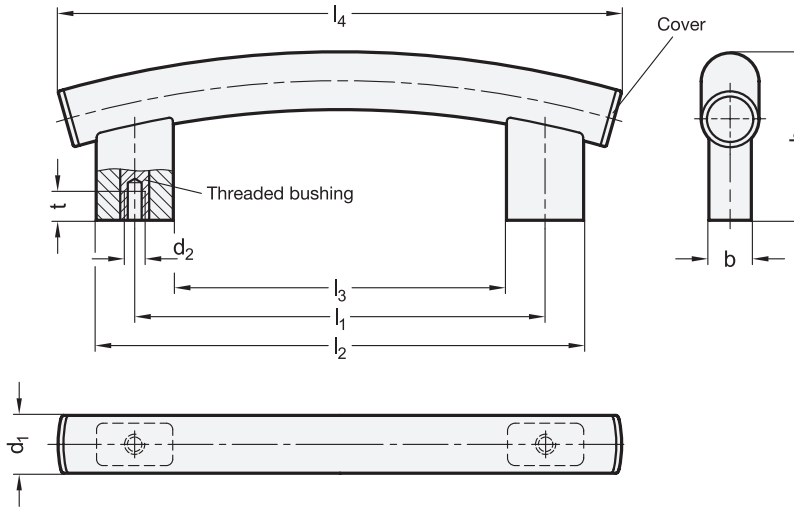

GN 666.4-SW

Description	d1	d2	l1 ±1	b	h	l2	l3	l4	t min.	⚖
GN 666.4-30-M6-400-SW	30	M 6	400	22	90	440	360	480	15	360
GN 666.4-30-M6-500-SW	30	M 6	500	22	94	540	460	580	15	420
GN 666.4-30-M6-600-SW	30	M 6	600	22	98	640	560	680	15	460
GN 666.4-30-M8-400-SW	30	M 8	400	22	90	440	360	480	15	350
GN 666.4-30-M8-500-SW	30	M 8	500	22	94	540	460	580	15	360
GN 666.4-30-M8-600-SW	30	M 8	600	22	98	640	560	680	15	395

GN 666.4-EL

Description	d1	d2	l1 ±1	b	h	l2	l3	l4	t min.	⚖
GN 666.4-30-M6-400-EL	30	M 6	400	22	90	440	360	480	15	360
GN 666.4-30-M6-500-EL	30	M 6	500	22	94	540	460	580	15	420
GN 666.4-30-M6-600-EL	30	M 6	600	22	98	640	560	680	15	460
GN 666.4-30-M8-400-EL	30	M 8	400	22	90	440	360	480	15	350
GN 666.4-30-M8-500-EL	30	M 8	500	22	94	540	460	580	15	360
GN 666.4-30-M8-600-EL	30	M 8	600	22	98	640	560	680	15	395

GN 666.4-ES

Description	d1	d2	l1 ±1	b	h	l2	l3	l4	t min.	⚖
GN 666.4-30-M6-400-ES	30	M 6	400	22	90	440	360	480	15	360
GN 666.4-30-M6-500-ES	30	M 6	500	22	94	540	460	580	15	420
GN 666.4-30-M6-600-ES	30	M 6	600	22	98	640	560	680	15	460
GN 666.4-30-M8-400-ES	30	M 8	400	22	90	440	360	480	15	350
GN 666.4-30-M8-500-ES	30	M 8	500	22	94	540	460	580	15	360
GN 666.4-30-M8-600-ES	30	M 8	600	22	98	640	560	680	15	395

GN 666.4-NG

STAINLESS STEEL

Description	d1	d2	l1 ±1	b	h	l2	l3	l4	t min.	⚖
GN 666.4-30-M6-400-NG	30	M 6	400	22	90	440	360	480	15	653
GN 666.4-30-M6-500-NG	30	M 6	500	22	94	540	460	580	15	776
GN 666.4-30-M6-600-NG	30	M 6	600	22	98	640	560	680	15	880
GN 666.4-30-M8-400-NG	30	M 8	400	22	90	440	360	480	15	618
GN 666.4-30-M8-500-NG	30	M 8	500	22	94	540	460	580	15	757
GN 666.4-30-M8-600-NG	30	M 8	600	22	98	640	560	680	15	875

